

# Guardian DELTA Flywheel Coupling

## Service & Installation Instructions

GUA-MRK-DOC-013

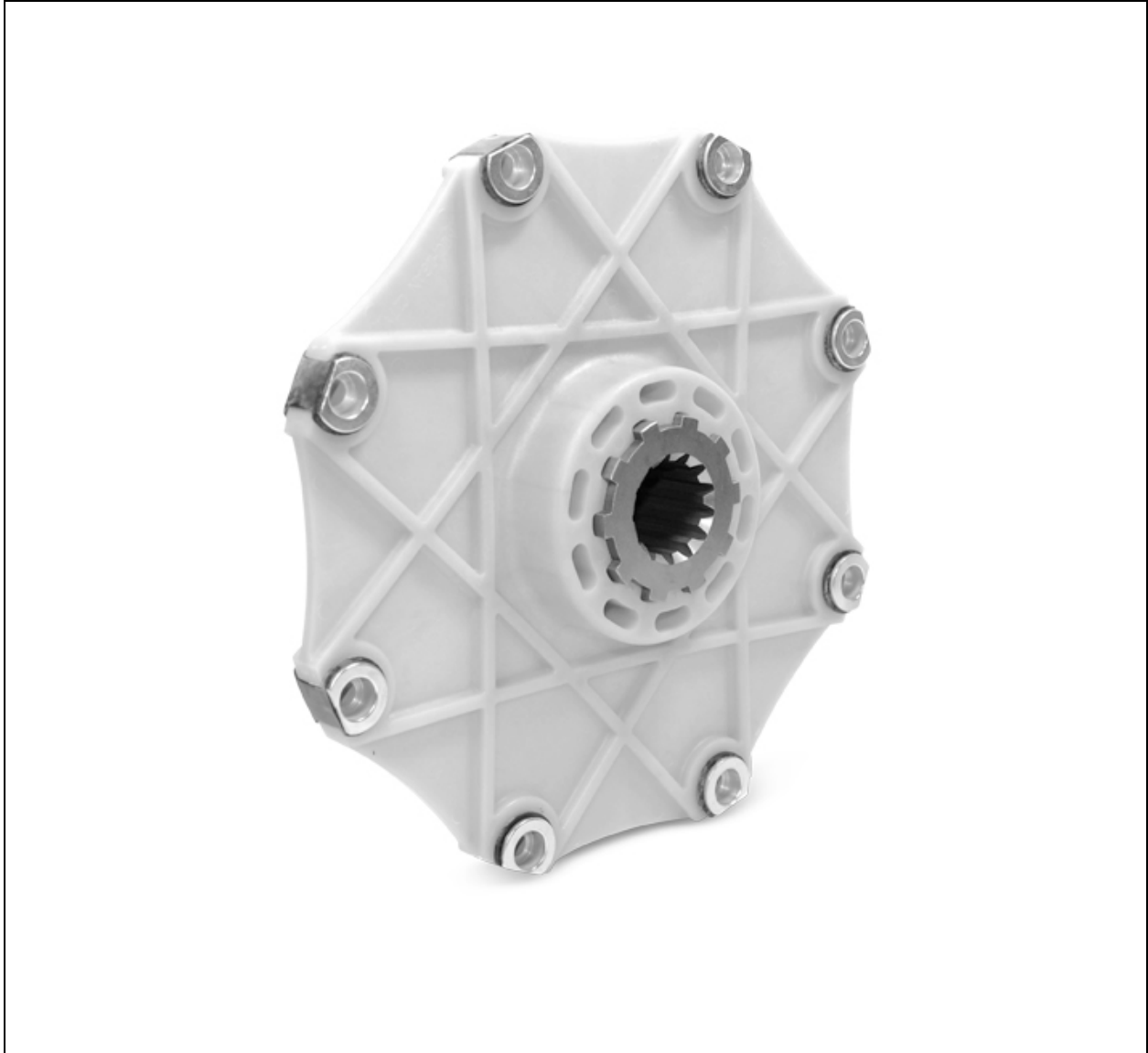

## TABLE OF CONTENTS

NOTICES AND WARNINGS	PAGE 2
SECTION 1 – COUPLING OVERVIEW	PAGE 3
SECTION 2 – TOOLS/MATERIALS REQUIRED	PAGE 5
SECTION 3A – INSTALLATION INSTRUCTIONS (SPLINE)	PAGE 5
SECTION 3B – INSTALLATION INSTRUCTIONS (STRAIGHT)	PAGE 5
SECTION 4 – REFERENCE DATA	PAGE 6
SECTION 5 – STORAGE	PAGE 6
WARRANTY	PAGE 8

### IMPORTANT READ ALL NOTICES & WARNINGS BEFORE ATTEMPTING ANY INSTALLATION!

#### NOTICES:

- PLEASE CAREFULLY READ OVER AND UNDERSTAND INSTRUCTIONS BEFORE ATTEMPTING ANY MAINTENANCE. IF ADDITIONAL ASSISTANCE IS NEEDED PLEASE CONTACT GUARDIAN BEFORE SERVICING/INSTALLING THE PRODUCT.
- WHILE GUARDIAN MAKES EVERY EFFORT TO ENSURE THE ACCURACY OF THE INFORMATION PROVIDED, WE MAKE NO WARRANTY AS TO THE ACCURACY OR COMPLETENESS OF SAID INFORMATION. THE INFORMATION PROVIDED CORRESPONDS TO THE INSTALLATION STANDARDS AT THE TIME OF PRINTING.
- THESE INSTALLATION INSTRUCTIONS ACT AS GENERAL GUIDELINES, AND DO NOT COVER EVERY SCENARIO. IF YOUR INSTALLATION DOES NOT APPLY, PLEASE CONTACT GUARDIAN TO FURTHER REVIEW YOUR APPLICATION TO ENSURE PROPER INSTALLATION IS COMPLETED.
- ENSURE PROPER SIZING AND OFFSETS TO AVOID CAUSING DAMAGE TO THE MACHINERY AND/OR COUPLING.
- KEEP COUPLINGS FREE OF DUST AND GRIME TO ENSURE LONG LIFE.
- VERIFY APPLICATION DATA AND REVIEW TORQUE SPECIFICATIONS, MIS-ALIGNMENT, AND APPLICATION SERVICE FACTORS. IF FURTHER ASSISTANCE IS NEEDED PLEASE CONTACT GUARDIAN COUPLINGS.
- CHECK TO MAKE SURE MAXIMUM ALLOWABLE BORE DIAMETERS ON HUBS ARE NOT EXCEEDED. SEE CATALOG SPECIFICATIONS FOR MORE DETAILS.
- HUBS THAT ARE MODIFIED OR MACHINED BY THE CUSTOMER ARE NOT COVERED UNDER THE STANDARD WARRANTY TERMS. IF MODIFICATIONS ARE MADE BY THE CUSTOMER IT IS RECOMMENDED THAT THE CUSTOMER ADHERES TO GUARDIAN MACHINING STANDARDS TO ENSURE PROPER OPERATION.

#### WARNINGS:

- DISENGAGE ALL POWER TO NECESSARY MACHINERY BEFORE PERFORMING ANY WORK ON THE ASSEMBLY. MAKE SURE NO ACCIDENTAL ENGAGEMENT CAN OCCUR.
- IMPROPER USE OR INSTALLATION MAY RESULT IN SERIOUS INJURY OR DEATH. GUARDIAN COUPLINGS WILL NOT BE LIABLE FOR IMPROPER USE/INSTALLATION OF THE PRODUCTS. THE PURCHASER/INSTALLER IS RESPONSIBLE FOR PROPER INSTALLATION, SAFEGUARDS, MAINTENANCE AND OPERATION OF THE PRODUCT AND EQUIPMENT.
- ANY MODIFICATIONS TO INSTRUCTIONS AND/OR COUPLING CHARACTERISTICS MAY RESULT IN A PREMATURE FAILURE.
- MAKE SURE THAT COUPLINGS ARE NOT IN CONTACT WITH ANY NON-ROTATING SURFACES.
- IF ANY PROBLEMS OCCUR DURING ASSEMBLY, CONTACT GUARDIAN COUPLINGS IMMEDIATELY.
- THIS PRODUCT CONTAINS WEAR ELEMENTS THAT WILL EVENTUALLY FAIL. MAKE SURE THE ASSEMBLY IS ADEQUATELY COVERED/ENCLOSED TO AVOID INJURY IN CASE OF A FAILURE.

## SECTION 1 – COUPLING OVERVIEW

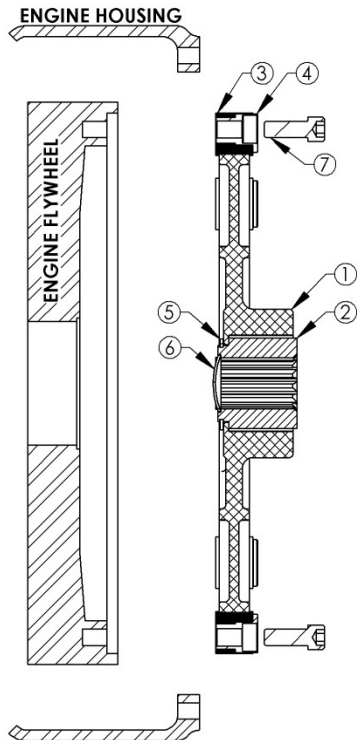

ITEM NUMBER	ITEM DESCRIPTION
1	DELTA COUPLING FLYWHEEL
2	DELTA COUPLING HUB
3	DELTA RUBBER GROMMET
4	DELTA STEEL INSERT
5	SNAP RING
6	GREASE PLUG (OPTIONAL)
7	COUPLING MOUNTING HARDWARE*

\*SHOWN FOR REFERENCE ONLY – NOT INCLUDED WITH COUPLING

FIGURE 1.1 DELTA COUPLING CROSS SECTION (SPLINED BORE)

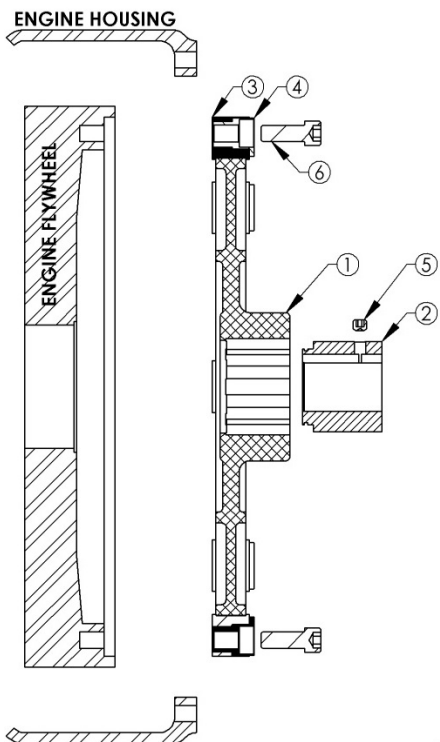

ITEM NUMBER	ITEM DESCRIPTION
1	DELTA COUPLING FLYWHEEL
2	DELTA COUPLING HUB
3	DELTA RUBBER GROMMET
4	DELTA STEEL INSERT
5	SETSCREW
6	COUPLING MOUNTING HARDWARE*

\*SHOWN FOR REFERENCE ONLY – NOT INCLUDED WITH COUPLING

FIGURE 1.2 DELTA COUPLING CROSS SECTION (STRAIGHT BORE)

**SECTION 1 – COUPLING OVERVIEW**

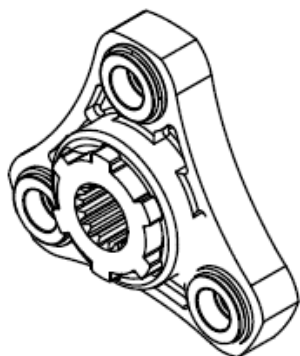

**FIGURE 1.3 DELTA SUPER 5 (PUMP SIDE)**

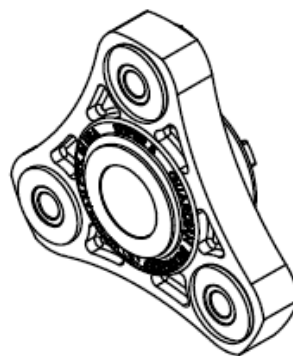

**FIGURE 1.4 DELTA SUPER 5 COUPLING (ENGINE SIDE)**

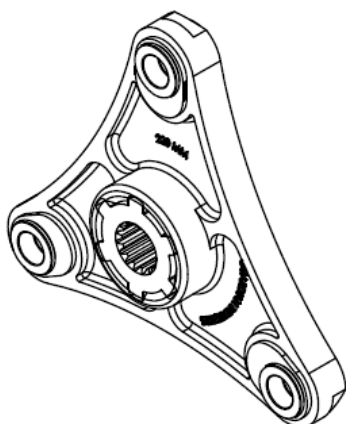

**FIGURE 1.5 DELTA SUPER 3 COUPLING (PUMP SIDE)**

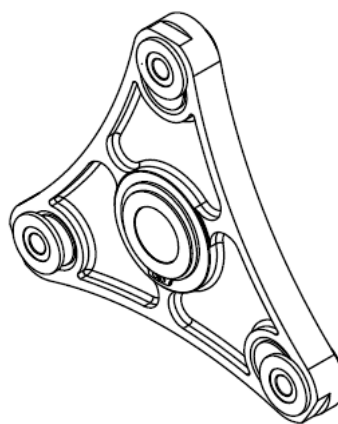

**FIGURE 1.6 DELTA SUPER 3 COUPLING (ENGINE SIDE)**

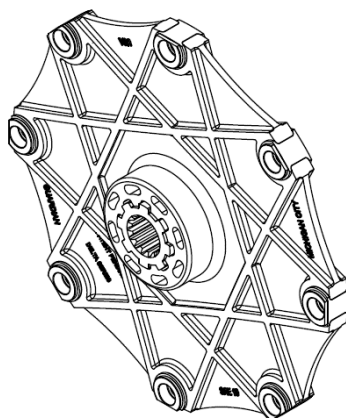

**FIGURE 1.7 DELTA SAE 10 COUPLING (PUMP SIDE)**

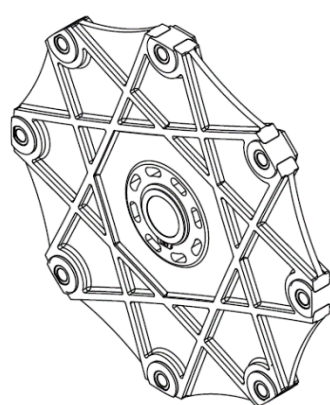

**FIGURE 1.8 DELTA SAE 10 COUPLING (ENGINE SIDE)**

## SECTION 2 - TOOLS/MATERIAL REQUIRED

- TORQUE WRENCH
- ALLEN SOCKETS
- CALIPERS
- MEDIUM STRENGTH REMOVABLE LOCTITE
- DELTA COUPLING GREASE (INCLUDED WITH COUPLING)

## SECTION 3A – INSTALLATION INSTRUCTIONS (SPLINED SHAFTS)

- 1) **PLEASE READ & FOLLOW ALL NOTICES & WARNINGS PRIOR TO INSTALLATION OF THIS PRODUCT  
DISENGAGE ALL POWER TO NECESSARY MACHINERY BEFORE PERFORMING ANY WORK ON THE ASSEMBLY  
MAKE SURE NO ACCIDENTAL ENGAGEMENT CAN OCCUR**
- 2) INSTALL AND MATE COUPLING WITH ENGINE FLYWHEEL PILOT AND MOUNTING HOLES  
COUPLING SHOULD BE INSTALLED WITH THE GREASE PLUG TOWARD THE ENGINE FLYWHEEL  
(IF YOUR COUPLING DOES NOT OFFER A GREASE PLUG, CONTACT GUARDIAN FOR FURTHER ASSISTANCE)
- 3) WITH COUPLING HOLES ALIGNED, INSTALL PROPER SIZED BOLTS INTO COUPLING MOUNTING HOLES  
GUARDIAN RECOMMENDS USING MEDIUM STRENGTH REMOVABLE LOCTITE  
(SEE TABLE 4.1 FOR STANDARD KUBOTA ENGINE FLYWHEEL HOLE SIZES)  
(SEE TABLE 4.2 FOR STANDARD SAE ENGINE FLYWHEEL HOLE SIZES)
- 4) ENSURING COUPLING IS FLAT WITH ENGINE FLYWHEEL, TORQUE BOLTS TO RECOMMENDED SEATING TORQUE  
(SEE TABLE 4.1 OR 4.2 FOR RESPECTIVE BOLT SEATING TORQUES)
- 5) APPLY LUBRICATING GREASE TO COUPLING SPLINE AND MATING SPLINED SHAFT  
GUARDIAN RECOMMENDS USING SHELL ALVANIA CG GREASE (GREASE SUPPLIED WITH COUPLING)
- 6) COUPLING IS NOW READY FOR INSTALLATION OF PUMP/ENGINE HOUSING  
REFER TO GUARDIAN'S SUPPLEMENTARY INSTALLATION INSTRUCTIONS FOR FURTHER ASSISTANCE

## SECTION 3B – INSTALLATION INSTRUCTIONS (STRAIGHT SHAFTS)

- 1) **PLEASE READ & FOLLOW ALL NOTICES & WARNINGS PRIOR TO INSTALLATION OF THIS PRODUCT  
DISENGAGE ALL POWER TO NECESSARY MACHINERY BEFORE PERFORMING ANY WORK ON THE ASSEMBLY  
MAKE SURE NO ACCIDENTAL ENGAGEMENT CAN OCCUR**
- 2) INSTALL AND MATE COUPLING FLANGE WITH ENGINE FLYWHEEL PILOT AND MOUNTING HOLES  
COUPLING SHOULD BE INSTALLED WITH THE FLANGE CENTER BOSS AWAY FROM THE ENGINE
- 3) WITH COUPLING HOLES ALIGNED, INSTALL PROPER SIZED BOLTS INTO ENGINE FLYWHEEL MOUNTING HOLES  
GUARDIAN RECOMMENDS USING MEDIUM STRENGTH REMOVABLE LOCTITE  
(SEE TABLE 4.1 FOR STANDARD KUBOTA ENGINE FLYWHEEL HOLE SIZES)  
(SEE TABLE 4.2 FOR STANDARD SAE ENGINE FLYWHEEL HOLE SIZES)
- 4) ENSURING COUPLING IS FLAT WITH ENGINE FLYWHEEL, TORQUE BOLTS TO RECOMMENDED SEATING TORQUE  
(SEE TABLE 4.1 OR 4.2 FOR RESPECTIVE BOLT SEATING TORQUES)
- 5) INSTALL AND MATE COUPLING HUB BORE WITH PUMP SHAFT AND KEY STOCK  
HUB SHOULD BE INSTALLED WITH TURNED NOSE AWAY FROM PUMP
- 6) USING CALIPERS, POSITION COUPLING HUB ON SHAFT TO OBTAIN REQUIRED ASSEMBLY GAP  
(SEE FIGURE 4.1 AND TABLE 4.4 FOR PROPER ASSEMBLY GAP)
- 7) WITH COUPLING HUB PROPERLY POSITIONED, TORQUE SETSCREW(S) TO RECOMMEND SEATING TORQUE  
GUARDIAN RECOMMENDS USING MEDIUM STRENGTH REMOVABLE LOCTITE  
(SEE TABLE 4.3 FOR PROPER SEATING TORQUES)
- 8) COUPLING IS NOW READY FOR INSTALLATION OF PUMP PLATE/ENGINE HOUSING  
REFER TO GUARDIAN'S SUPPLEMENTARY INSTALLATION INSTRUCTIONS FOR FURTHER ASSISTANCE

## SECTION 4 - REFERENCE DATA

**TABLE 4.1 KUBOTA ENGINE FLYWHEEL HOLE SIZES AND SEATING TORQUES**

KUBOTA ENGINE SERIES		SUPER 3 – 165	SUPER 3 - 185	SUPER 5
METRIC BOLTS		M8	M10	
SEATING TORQUE	FT-LBS	20	40	
	Nm	27	54	

**TABLE 4.2 SAE – J620d ENGINE FLYWHEEL HOLE SIZES AND SEATING TORQUES**

SAE FLYWHEEL SIZE		6-1/2	7-1/2	8	10	11-1/2	14	18
IMPERIAL BOLTS		5/16-18			3/8-16		1/2-13	5/8-11
SEATING TORQUE	FT-LBS	19			34		85	170
	Nm	26			46		115	230
METRIC BOLTS		M8			M10		M12	M16
SEATING TORQUE	FT-LBS	20			40		70	155
	Nm	27			54		95	210

**TABLE 4.3 DELTA COUPLING SERIES MOUNTING SETSCREWS**

DELTA COUPLING SERIES		SUPER 3 KEA	SUPER 5 KEA	SAE 10
IMPERIAL SETSCREWS		5/16-18		
SEATING TORQUE	FT-LBS		14	
	Nm		19	
METRIC SETSCREWS		M8		
SEATING TORQUE	FT-LBS		13	
	Nm		18	

**TABLE 4.4 DELTA COUPLING SERIES ASSEMBLY GAP**

DELTA COUPLING SERIES	SUPER 3 KEA	SUPER 5 KEA	SAE 10 – SD (8T)	SAE 10 – HD (10T)
ASSEMBLY GAP	.79 <sup>1</sup>	.48 <sup>2</sup>	.63 <sup>3</sup>	.53 <sup>3</sup>

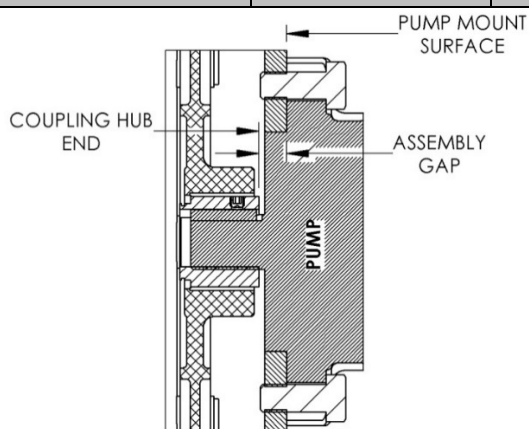

**FIGURE 4.1 DELTA HUB ASSEMBLY GAP**

<sup>1</sup>SUPER 3 ASSEMBLY GAP BASED ON PUMP HOUSING LENGTH OF 2.070" AND A FLYWHEEL OFFSET OF .197"

<sup>2</sup>SUPER 5 ASSEMBLY GAP BASED ON PUMP HOUSING LENGTH OF 3.940" AND A FLYWHEEL OFFSET OF 2.070"

<sup>3</sup>SAE 10 SD/HD ASSEMBLY GAP BASED ON PUMP PLATE THICKNESS OF .500" AND A FLYWHEEL OFFSET OF 2.120"

## SECTION 5 - STORAGE

- COUPLINGS SHOULD BE STORED IN A DRY, WELL MAINTAINED ENVIRONMENT
- HUMID STORAGE ENVIRONMENTS COULD LEAD TO SURFACE RUST ON THE HUB AND BORE (INSPECT BORE FOR RUST AND BURRS PRIOR TO INSTALLATION)
- COUPLING SHOULD BE STORED WITH RUBBER GROMMETS FREE OF OIL



## WARRANTY

Guardian Ind. Inc. warrants that the Goods will be free from defects in material and workmanship for a period of twelve (12) months from delivery, or such other period as shall be agreed upon in writing by the parties. Guardian Ind. Inc.'s limited warranty excludes remedy for damage or defect caused by abuse; failure to resist corrosion or erosion from any corrosive agent or fluid, or due to deposits of foreign material from any fluid; modifications not executed by Guardian Ind. Inc.; improper installation or operation; defects or failures arising out of, in any way related to, or as a result, either direct or indirect, of the Buyer's failure to properly advise Guardian Ind. Inc. of all normal and special operating conditions, known to or suspected by the Buyer, when Guardian Ind. Inc. is manufacturing the Product for a specific operation; or normal wear and tear under normal usage. All weights stated in Guardian Ind. Inc.'s catalog and lists are approximate and are excluded from this warranty. EXCEPT AS EXPRESSLY SET FORTH IN THIS PARAGRAPH, GUARDIAN IND. INC. MAKES NO OTHER WARRANTY WITH RESPECT TO THE GOODS DELIVERED HEREUNDER AND EXPRESSLY DISCLAIMS ALL OTHER WARRANTIES, EXPRESS OR IMPLIED, INCLUDING WARRANTIES OF MERCHANTABILITY AND OF FITNESS FOR A PARTICULAR PURPOSE, ARISING BY OPERATION OF LAW OR OTHERWISE.

Guardian Ind. Inc. must be notified in writing of any defect in the Goods within a reasonable period of time after discovery (not to exceed thirty (30) days) and the defective Goods must be delivered within the warranty period specified above, prepaid, to Guardian Ind. Inc.'s factory, with evidence that the Goods have been properly installed, maintained and operated in accordance with Guardian Ind. Inc.'s instructions. If Guardian Ind. Inc. determines that any such returned Goods are not in conformity with the warranty set forth herein, then Guardian Ind. Inc. shall, at its sole option and expense, either repair the same or supply replacement Goods.

The remedies of Buyer set forth herein are exclusive, and the total liability of Guardian Ind. Inc. hereunder, whether based on contract, warranty, negligence, indemnity, strict liability or otherwise, and shall not exceed the purchase price of the Goods giving rise to any such claim for liability. IN NO EVENT SHALL GUARDIAN IND. INC. OR ITS SUPPLIERS BE LIABLE TO BUYER, ANY SUCCESSORS IN INTEREST, OR ANY BENEFICIARY OF THIS CONTRACT FOR CONSEQUENTIAL, INDIRECT, INCIDENTAL, OR SPECIAL DAMAGES OR LOSSES, OR FOR ANY SECONDARY CHARGES OR ADMINISTRATIVE OR PUNITIVE DAMAGES, FINES, PENALTIES, FEES, EXPENSES AND OTHER CHARGES, ARISING OUT OF THE CONTRACT OR ANY BREACH THEREOF, WHETHER BASED UPON LOSS OF USE, LOSS OF PRODUCTION, LOST PROFITS OR REVENUE, INTEREST, LOST GOODWILL, WORK STOPPAGE, IMPAIRMENT OF OTHER GOODS, LOSS BY REASON OF SHUTDOWN OR NON-OPERATION, INCREASED EXPENSES OF OPERATION OR CLAIMS OF CUSTOMERS OF BUYER FOR SERVICE INTERRUPTION, OR ANY OTHER TYPE OF ECONOMIC LOSS OR DAMAGE, WHETHER OR NOT SUCH LOSS OR DAMAGE IS BASED ON CONTRACT, WARRANTY, NEGLIGENCE, INDEMNITY, STRICT LIABILITY OR OTHERWISE.

Further details pertaining to TERMS AND CONDITIONS OF SALES can be found at the following link:

[http://www.altramotion.com/~media/Files/Corporate/Terms%20and%20Conditions/Sales-Terms/Guardian\\_Sales\\_Terms.ashx](http://www.altramotion.com/~media/Files/Corporate/Terms%20and%20Conditions/Sales-Terms/Guardian_Sales_Terms.ashx)



[www.guardiancouplings.com](http://www.guardiancouplings.com)

300 Indiana Highway 212  
Michigan City, IN 46361  
219-874-5248  
Fax: 219-879-6643

